

HOKUYO Safety Laser Scanner

Area detection



HOKUYO



SCHMERSAL
THE DNA OF SAFETY

Overview

Compact and user friendly

Compact design for installation on AGVs and AGCs, as well as in safety guarding applications.

Size: 95 x 80 x 80 mm
3.75 x 3.15 x 3.15 inches

Weight: 0.5 kg

Conformity to standards:

IEC61469-1/3	Type 3
IEC61508	SIL2
ISO13849-1	PLd Category 3
UL508	
UL1998	
UL61496-1	Type 3
CSA C22.2	No. 14



Easy configuration of complicated zones

User friendly interface

Simple user interface to configure even a complicated zone by simultaneously viewing the measurement data. Zones can be configured with 3 different methods

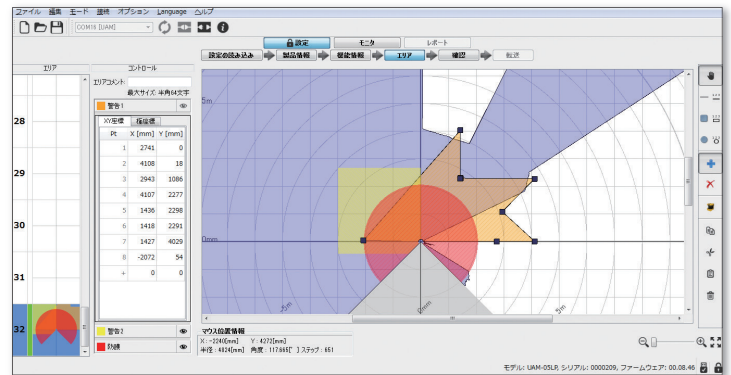
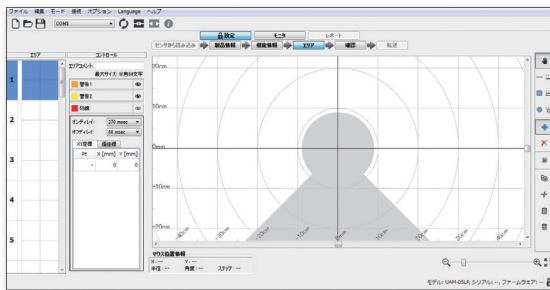

Applications

Collision protection

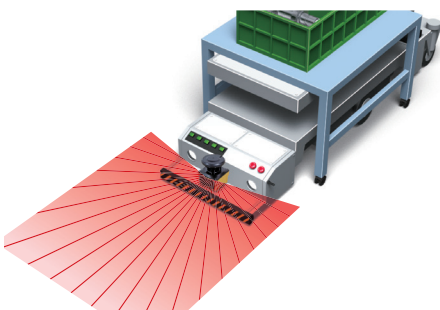

32 safety area patterns to accommodate the AGV travel path for collision protection

Presence detection

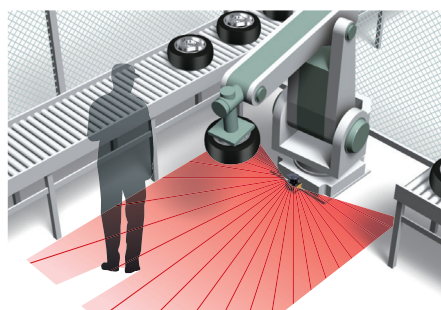

Detects humans or objects entering the hazardous area.

Intrusion detection

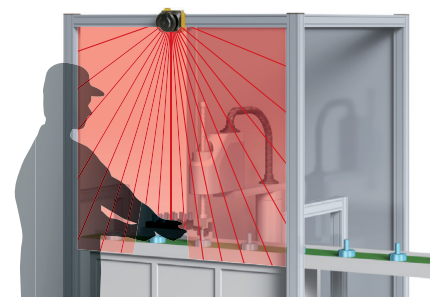

Detects access into critical zone at point of operation.

Features

Protection over a wide range

Up to 5 meters of protection zone and 20 meters of warning zone configuration to suit various application requirements.

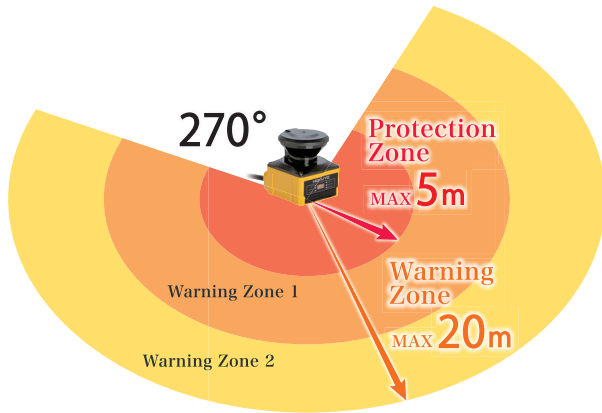

Data output via Ethernet

Measurement data can be acquired via Ethernet, with status of input/output signals and cyclic redundancy check code. Also supports command in SCIP2.0 protocol.

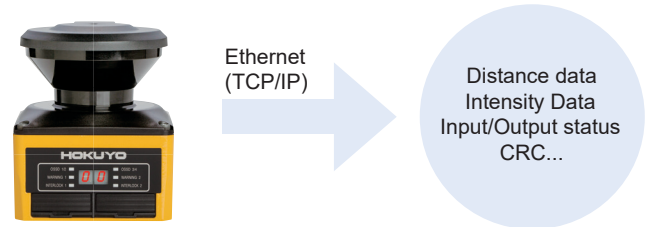

SD card for configuration

Configuration data can be saved to a SD card, which in turn can be used for configuring the UAM without connecting a PC. The Feature is useful while replacing the UAM or configuring multiple units with the same settings.



Master-Slave function

Up to 4 units can be interconnected for Master-Slave operation when multiple units are required to guard the hazardous area. The system can be controlled by connecting the input and output signals to Master unit only. Important note: It is not possible to control actuators via master-slave bus communication.

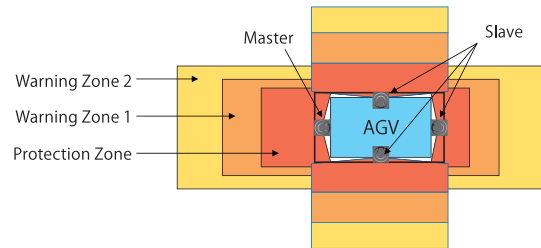

Encoder input

In AGV applications, area is switched depending on the vehicle's speed. Speed and direction of travel provided via encoders are constantly monitored to switch the area and stop the AGV during abnormal travel.

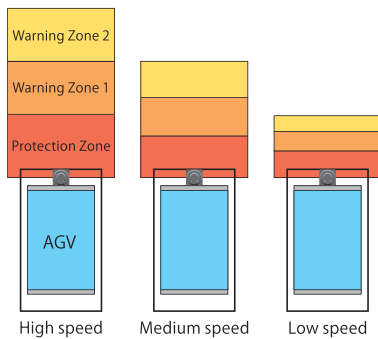

Dual protection mode

The scanner can simultaneously protect two adjacent hazardous areas. Separate OSSD signals are triggered for the respective protection zones making it possible to guard two machines with a single scanner unit.

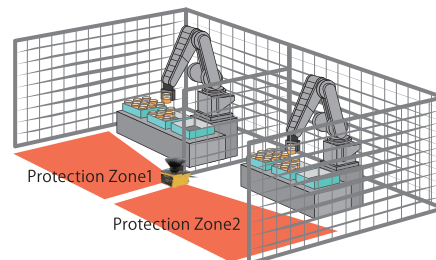

System components

Main unit



Model number	Description
UAM-05LP-T301	Scanner, 3m cable with flying leads, software included
UAM-05LP-T301C	Scanner, 300mm cable with connector, software included

Extension cable without connector (For T301 model)



Model number	Description
UAM-5C10	Cable length: 10 m
UAM-5C20	Cable length: 20 m

Extension cable with connector (For T301C model)

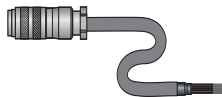

Model number	Description
UAM-5C02C	Cable length: 2 m
UAM-5C05C	Cable length: 5 m
UAM-5C10C	Cable length: 10 m
UAM-5C20C	Cable length: 20 m

Brackets and Accessories

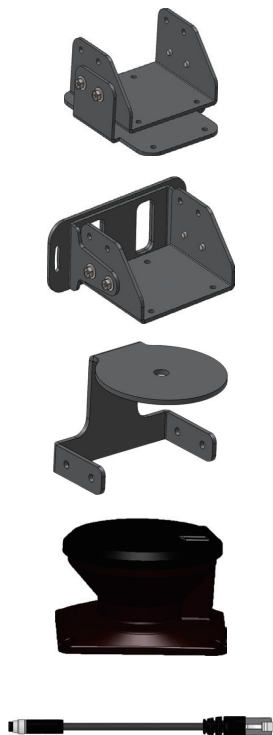

Model number	Description
UAM-BK03	Base mounting bracket
UAM-BK04	Rear mounting bracket
UAM-BK05	Cover bracket (protect the optical window)
UAM-W002	Replacement optical window (lens)
UAM-ENET	Ethernet cable, Length: 3 m

Specifications

Detection property	Protection range	Max: 5 m
	Warning range	Max: 20 m (non-safety) *1
	Distance tolerance *2	+100 mm
	Direction capability	From black-reflector sheet (1.8%) to retro-reflector sheet
	Detection angle	270°
	Minimum width / detectable distance	Ø 30 mm, max: 1.8 m Ø 50 mm, max: 3.0 m Ø 70 mm, max: 5.0 m
	Scan frequency	30 ms (rotational speed 2000 rpm)
	Area pattern	Max 32 patterns for safety and 64 patterns for non-safety
	Response time	OFF 60 ms ~ 510 ms / ON 270 ms ~ 510 ms
Optics	Element	Pulsed laser diode
	Wave length	905 nm
	Safety Class	Laser class 1
Type	Type 3 (IEC 61496-1, IEC 61496-3)	
Functional Safety	SIL2 (Type B, HFT=1) (IEC 61508)	
PFH _d	7.8x10 ⁻⁸ (T1=20 year): When master-slave function not in use 1.6x10 ⁻⁷ (T1=20 year): When master-slave function in use	
Housing	Size	80.0 mm (W), 80.0 mm (D), 95.0 mm (H), without cable
	Weight	0.5 kg
	Protection	IP65
	Case material	Body: Aluminium, Optical window: polycarbonate
	Connection cable	T301: Flying lead cable: 3 m T301C: Cable with IP67 connector, cable 0.3 m
Power Supply	DC 24 V ±10% when using converter power supply DC 24 V -30%/+20% when using battery	
Supply current	Normal (without load)	6 W
	Max. (with load)	50 W
Output	OSSD 1/2 (Safety)	Output type: high side SW Output current: Max 500 mA *3 Leak current: Max 1 mA AWG 26 Load tolerance: L/R = 25 ms, C=1µF
	OSSD 3/4 (Safety) WARNING 1/2 (non-safety)	Output type: high side SW Output current: Max 250 mA *3 Leak current: Max 1 mA AWG 28 Load tolerance: L/R = 25 ms, C=1µF
	RES_REQ 1, RES_REQ 2 MUT_OUT 1, MUT_OUT 2	Output type: PNP Transistor Output current: max 200 mA *3 Leak current: Max 1 mA AWG 28
Input	Input impedance 4.7 kΩ AWG28	
Interface	Configuration	USB2.0 (USB micro type-B connector)
	Data output	Ethernet 100BASE-TX (waterproof connector)
Environmental resistance	Temperature	-10°C to +50°C (no freezing) Storage: -25°C to +70°C (no freezing)
	Humidity	95% RH with no condensation Storage: 95% RH with no condensation
	Surrounding intensity *4	Less than 1500 lx
	Vibration	Frequency range: 10~55 Hz Sweep rate: 1 octave/min Amplitude: 0.35 mm ±0.05 mm
Bump	Acceleration: 98 m/s ² (10G) Pulse duration: 16 ms	
Outdoor operation	Not permitted	
Altitude	Below 2000 m	

*1 Distance when reflectance of the object is 90% or above.

*2 Additional distance of 200 mm is needed when UAM is working under high reflective background.

*3 Total current supply of OSSD output and Warning output should be below 1.0A.

*4 When the light sources are located at ≥5° from the detection plane of UAM.

Wiring

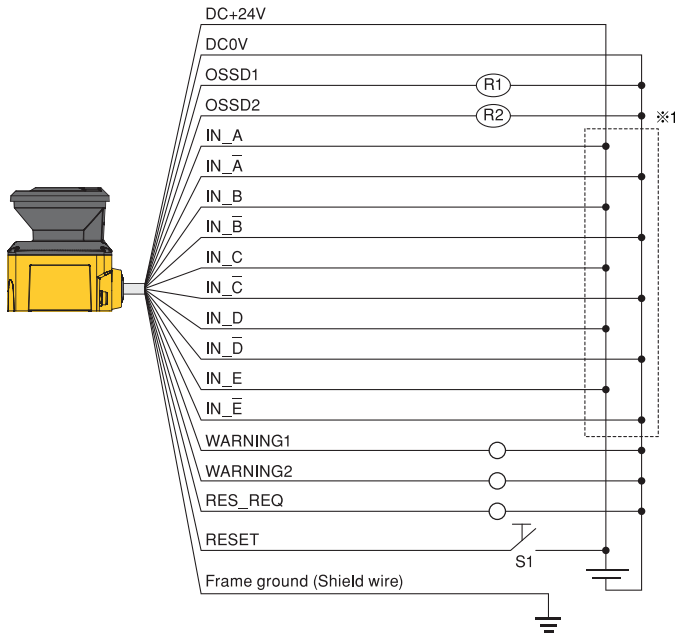

R1 and R2 : External equipment (Safety relay, Electromagnetic contactor)
S1: Interlock reset switch

*1: Refer to user's manual for details on area switching.

Color	Signal	Function	Description	AWG
Brown	+24V DC	Power	Power Supply DC 24V	22
Blue	0V DC	Power	Power Supply DC 0V	22
Red	OSSD1	Output	Protection zone output 1	26
Yellow	OSSD2	Output	Protection zone output 2	26
Red/Black	OSSD3 WARNING1	Output	Protection zone output 3 Warning zone output 1	28
Yellow/Black	OSSD4 WARNING2	Output	Protection zone output 4 Warning zone output 2	28
Purple	IN_A	Input	Area switching input A	28
Gray	IN_B MUTING3	Input	Area switching input B Muting input 3	28
White	IN_C OVERRIDE1 ENC1_A	Input	Area switching input C Override input 1 Encoder input 1_A	28
Pink	IN_D MUTING1 ENC1_B	Input	Area switching input D Muting input 1 Encoder input 1_B	28
Green	IN_E EDM1	Input	Area switching input E External device monitoring 1	28
Purple/Black	IN_A	Input	Area switching input A invert	28
Gray/Black	IN_B MUTING4	Input	Area switching input B invert Muting input 4	28
White/Black	IN_C OVERRIDE2 ENC2_A	Input	Area switching input C invert Override input 2 Encoder input 2_A	28
Pink/Black	IN_D MUTING2 ENC2_B	Input	Area switching input D invert Muting input 2 Encoder input 2_B	28
Green/Black	IN_E EDM2	Input	Area switching input E invert External device monitoring 2	28
Yellow/Green	RESET1	Input	Reset input 1	28
Yellow/Blue	RESET2	Input	Reset input 2	28
Orange	RES_REQ1 MUT_OUT1	Output	Request output 1 Muting state output 1	28
Orange/Black	RES_REQ2 MUT_OUT2	Output	Request output 2 Muting state output 2	28
White/Blue (TP)	RS485+	Comm	Communication protocol RS485	28
White/Red (TP)	RS485-	Comm	Communication protocol RS485	28
Shield wire	FG	--	Frame ground	--

Input / Output circuit

OSSD output circuit
OSSD/Warning output is output type.

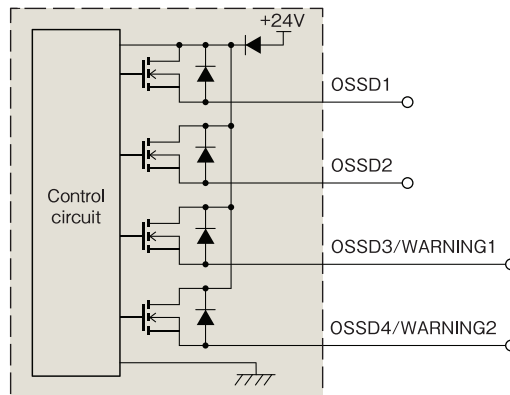

Other Output circuit
RES_REQ1, RES_REQ2, MUT_OUT1, MUT_OUT2 output circuit.

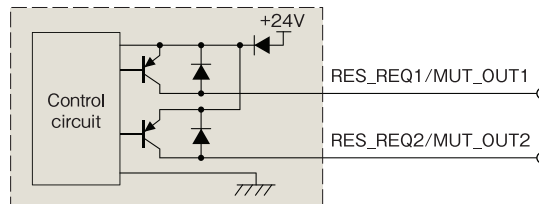

Input circuit
Area input, EDM1, EDM2, RESET1, RESET2, MUTING1, MUTING2, MUTING3, MUTING4, OVERRIDE1, and OVERRIDE2

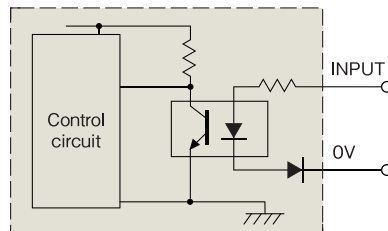

Diagrams

UAM-05LP-T301

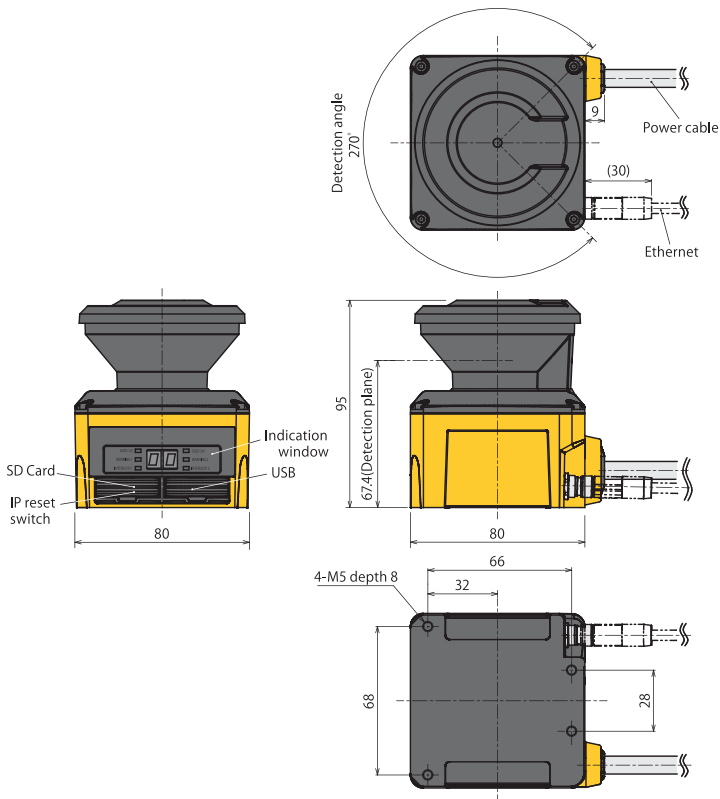

UAM-05LP-T301C

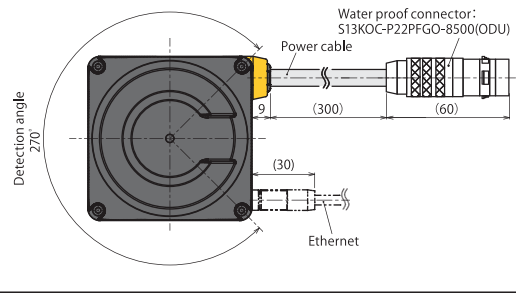

Rear mounting bracket with Cover bracket

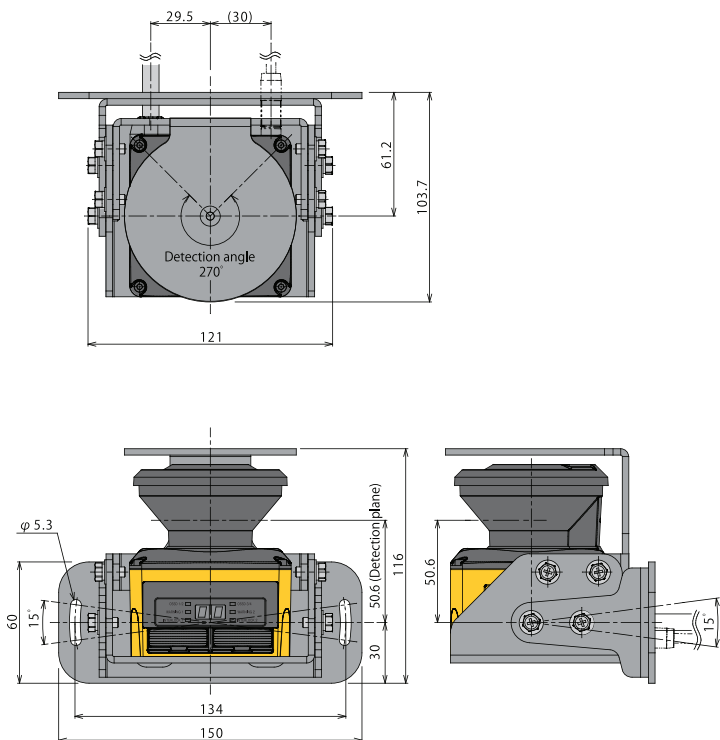

Base mounting bracket with Cover bracket

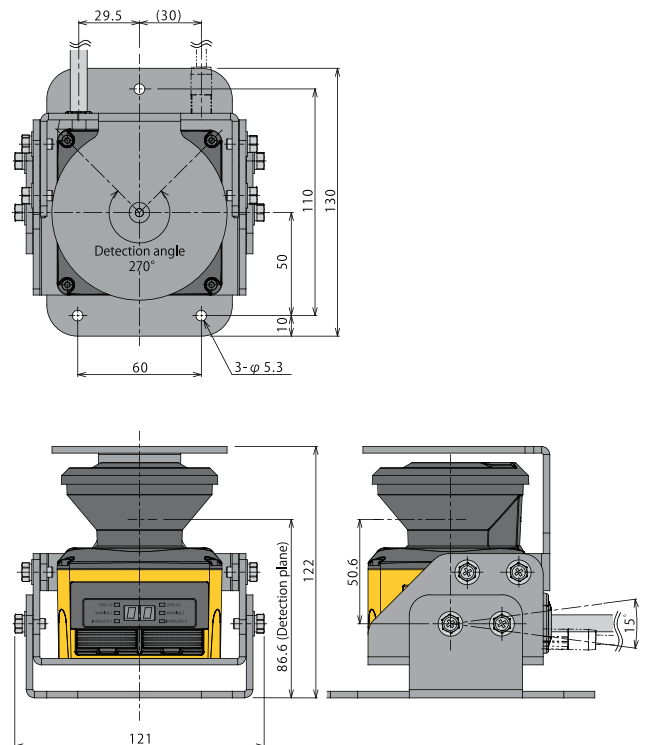



Schmersal Nordiska AB

F O Petersons gata 28
421 31 Västra Frölunda

Tel: +46 31 338 35 00
info-se@schmersal.com
www.schmersal.se

Schmersal Danmark A/S

Arnold Nielsens Boulevard 72-74
2650 Hvidovre

Tel: +45 70 20 90 27
info-dk@schmersal.com
www.schmersal.dk